

# The Maze Trick, Assessment.

---

## Teachers Notes

This task has been developed from resources in Australian Academy of Science 2008, *Light fantastic*.

In this task students are asked to construct a model of a maze using a specific template and then are challenged to transmit light through the maze using mirrors.

This challenge gives students an opportunity to apply problem-solving skills and access their knowledge of light, specifically reflection.

The second challenge requires students to alter the appearance of the light in some way. It is expected that the students will draw on their knowledge of shadows and their knowledge of reflection, refraction and absorption of light developed throughout the unit.

It is important to note that this is an independent task requiring the students to have their own box/maze and mirrors.

## Challenge 1

### Resourcing

- The task asks for the use of a small box. The ideal box would be a shoebox as the lid can be removed and replaced easily. Many shoe stores are happy to give spare shoeboxes to schools. If a shoebox is not an option, then a cereal box or similar sized box will also work, although the top of these will need to split to create barnyard-like doors. If you have used shoeboxes in earlier lessons, then it is recommended that these be used.
- Cardboard is required for the construction of the walls of the maze. Any cardboard is fine to use; however, it would be easier with a slightly heavier card than normal. Manilla folders are a good option. Old greeting cards can be ideal.
- This task also requires the use of mirrors. It is ideal to use plastic safety mirrors, but this may be difficult, as each child needs constant access to at least four mirrors. A good replacement is metallic card. The task has been completed with the use of metallic card and the photos that follow are of a maze completed in such a way.
- Torches are also required. It would be ideal for students to have access to individual torches; however, they can share these among small groups if necessary.

## Construction

**Walls:** The walls of the maze should not prove too difficult; however, they do need to fit in the maze. Students will need to cut walls to the correct size. The walls should be the height of the box and less than half as wide as the box. Some students will need more support with this than others. Give as much support as necessary as this is not being assessed. Below are a couple of pictures showing how to construct the walls. This method will give walls the required support, and they should stand easily with the use of tape.

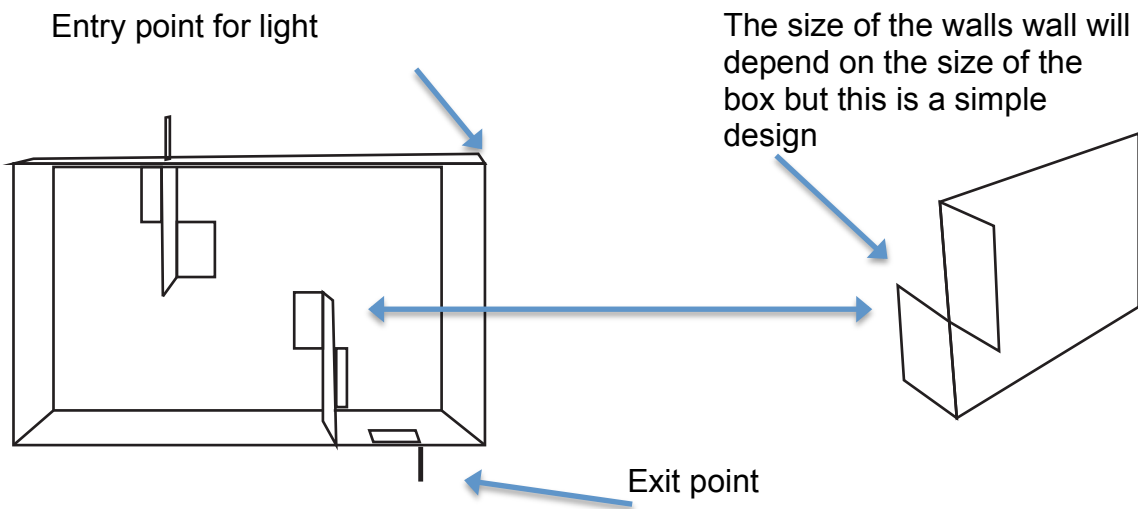

- **Doorways:** As with the walls, this could prove somewhat difficult for students so they may require adult assistance. Scissors can be used. You can see the doorways in later photos.

## Implementation

Allow students time to explore the best ways to solve this challenge. At first it will seem quite easy, but as they go on it will become clear that there are many variables that will affect their success.

## Challenge 2

### Implementation

This will require students to think of different ways they can alter the appearance of light. This is a deceptively simple task. The assessment comes in the form of their ability to apply science inquiry skills and explain different aspects of light.

There are many ways students could change the appearance of the light. Below are some ideas:

- Change the colour — Use cellophane or other coloured transparent or even translucent material.
- Change the shape — Place an opaque object in the light's path.
- Increase the brightness — Use focussing mirrors.
- Refract the light to create a rainbow — Place a glass of water in the light's path.

Here are some more pictures showing the maze, how the light travels through the maze and what it should look likes as it exits

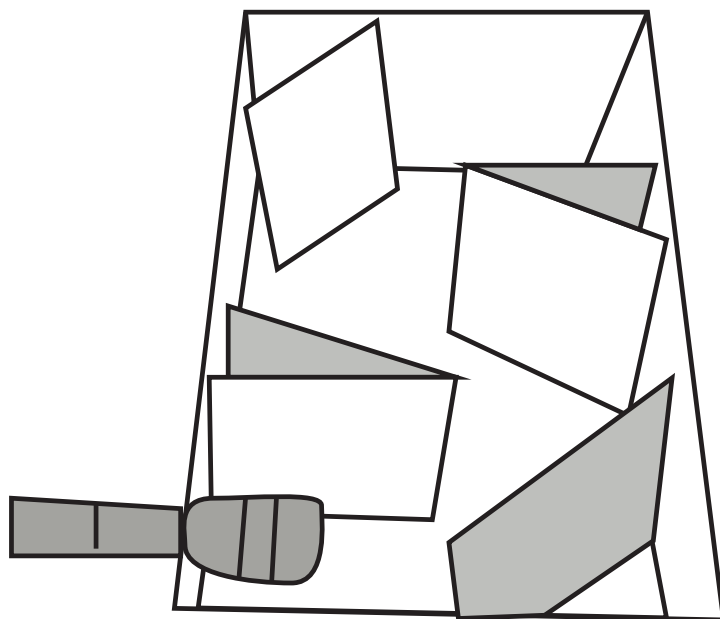
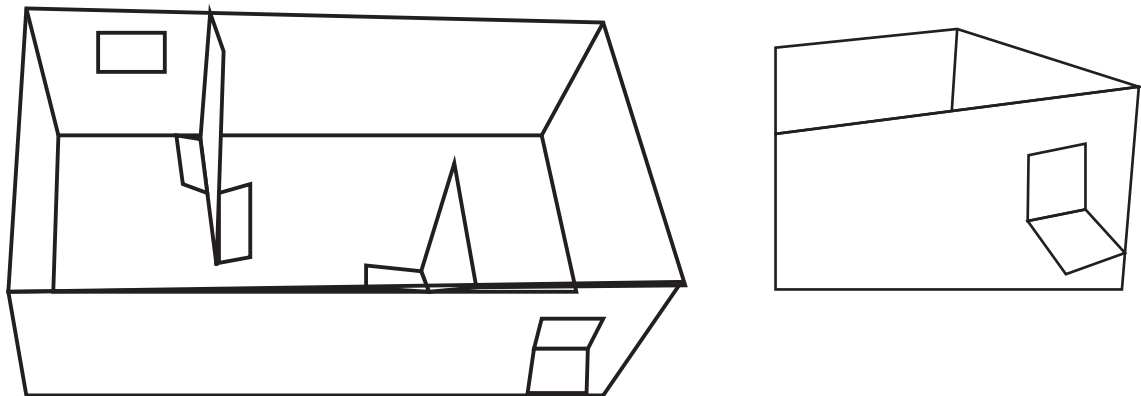

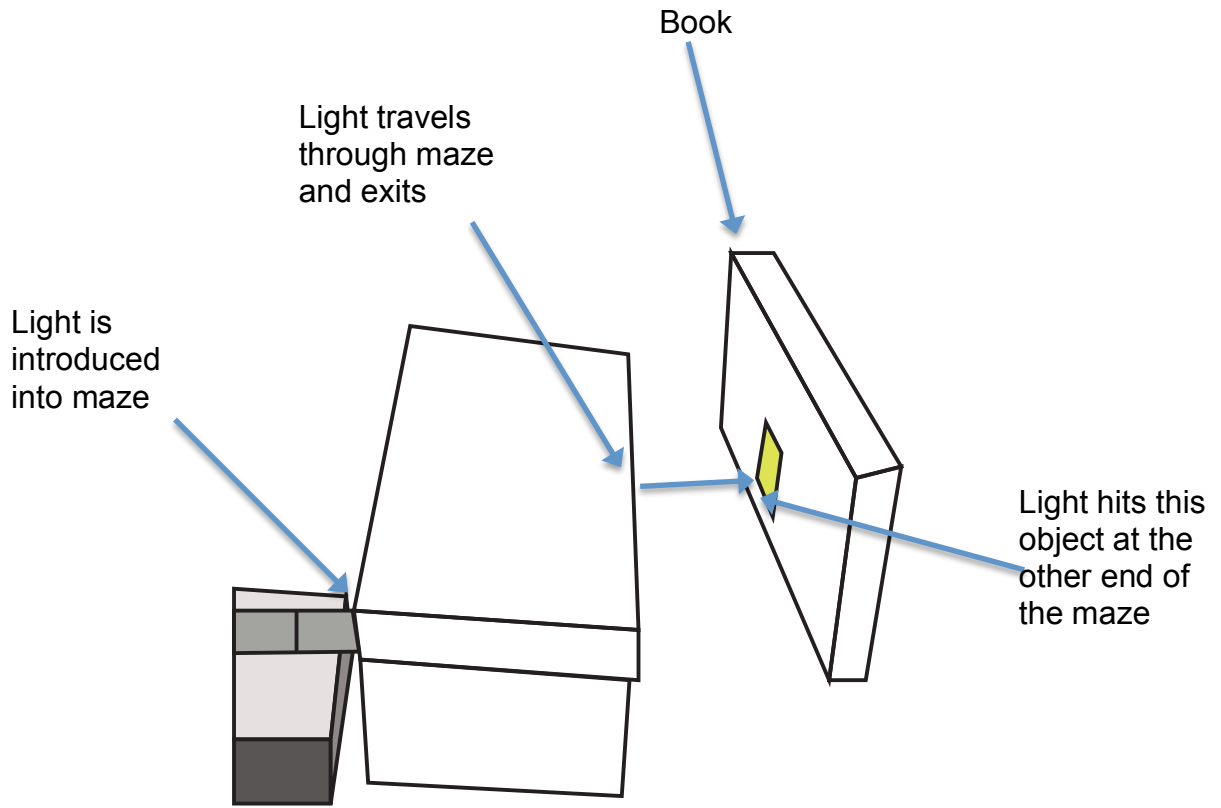

References:

- Australian Academy of Science 2008, *Light fantastic*, [Rev. ed.], Canberra, ACT Australian Academy of Science
- Australian Curriculum, Assessment and Reporting Authority (ACARA), *Australian Curriculum v3.0: Science for Foundation–10*  
<[www.australiancurriculum.edu.au/Science/Curriculum/F-10](http://www.australiancurriculum.edu.au/Science/Curriculum/F-10)>. Retrieved 22<sup>nd</sup> September 2013
- Bybee, Rodger W 1997, *Achieving scientific literacy: from purposes to practices*, Heinemann, Portsmouth, NH: Heinemann
- Education Queensland, Department of Education Training and Employment 2013, ' Assessment', Retrieved 10<sup>th</sup> November 2013.  
<<http://education.qld.gov.au/staff/learning/diversity/teaching/assessment.html>>
- Hackling, M. W. & Prain, V. 2005. Primary Connections: Stage 2 research report. Canberra: Australian Academy of Science.  
[http://www.acer.edu.au/documents/RC2006\\_Hackling.pdf](http://www.acer.edu.au/documents/RC2006_Hackling.pdf) Retrieved 22<sup>nd</sup> September 2013
- Skamp, Keith 2012, *Teaching primary science constructively*, 4th ed, Cengage Learning, South Melbourne, Vic